



Thank you for choosing the Team Magic E4RSII. Before you start building the E4RSII, we suggest you read through the instruction manual first. Be sure to check all assembly and performance tips before you start. We hope you enjoy the fine building processes.

General Building Tips:

- ▶ Read the instruction manual before building.
- ▶ Clear a work area and try to work on a light color towel to avoid missing dropped parts.
- ▶ Don't forge the thread lock. Be certain to use thread-lock on all the machine screws that thread into metal. Put it on the screws that are secured with locknuts and the setscrews that secure the linkage stops, too. Don't skimp on the thread-lock or you'll be searching in the dirt for screws that vibrated loose.
- ▶ Don't over-tighten fasteners. Many assembly problems are caused by over-tightening screws or nuts. Don't use too large a grip. Please go slowly and feel the resistance build. Just snug it up.
- ▶ As you put more time and runs on the car, the suspension arms, and basically anything else that moves, can stretch and wear. Though we have a very rigorous quality control program and make every effort to ensure that the parts have the best possible fit when you get them. Unfortunately there is very little, or nothing we can do to prevent these parts from wearing out. When the arms begin to wear you will notice that some slop develops between the carrier or hub and the arms. This slop can be taken out by shimming the arm, hub or carrier. If you take a look at any of the factory driver's cars you will definitely find that they use shims to take up some of the slop that occurs over a period of time. The shims can also be used on the inside of the suspension arms in the same manner. When shimming the parts, care must be taken not to add too many shims. The parts must still move freely without binding.
- ▶ When it doesn't fit, please double check. If an assembly is not going together correctly, then either there really is a bad fit (e.g. a part is damaged or defective) or a mistake in assembly. Always re-read the instructions when there are any problems. If you cannot figure out what's wrong, always ask dealer, distributor or Team Magic. Don't use force beyond what the instructions call for.
- ▶ Using the right tools makes assembly much easier. The instructions below finely indicate you what tools to get to make things easier. We don't want to scare you by saying that all these tools are required, but you will have an easier time if you have them. Borrow them from a friend to check if necessary.
- ▶ The assembly is arranged so that you will open the bag and finish that bag before you go on to the next bag. Sometimes, you will have parts remaining at the end of a bag. These will become part of the following bags.

A Good Dealer Is Extremely Important!!

A good hobby dealer can help you with most assembly problems you might encounter. This is the main reason why you should buy your kits from a good dealer rather than from the cheapest dealer. Bring your problematic parts to the dealer and, most likely, you'll walk away soon thereafter with the problem solved. If you think that you really don't have the mechanical skills to complete the assembly, you may pay your dealer to finish the job for you. We can recommend good dealers to you if you need. Please send us mails for more information. Email: service@teammagic.com.tw



130114
3X6X1mm Washer



126306
3x6mm Steel FH
Screw



150510ST
5x10x4mm Steel
Bearing



116203
E-clip 5



116238
2x12.8mm Pin



126304BU
M3X4mm BH Screw

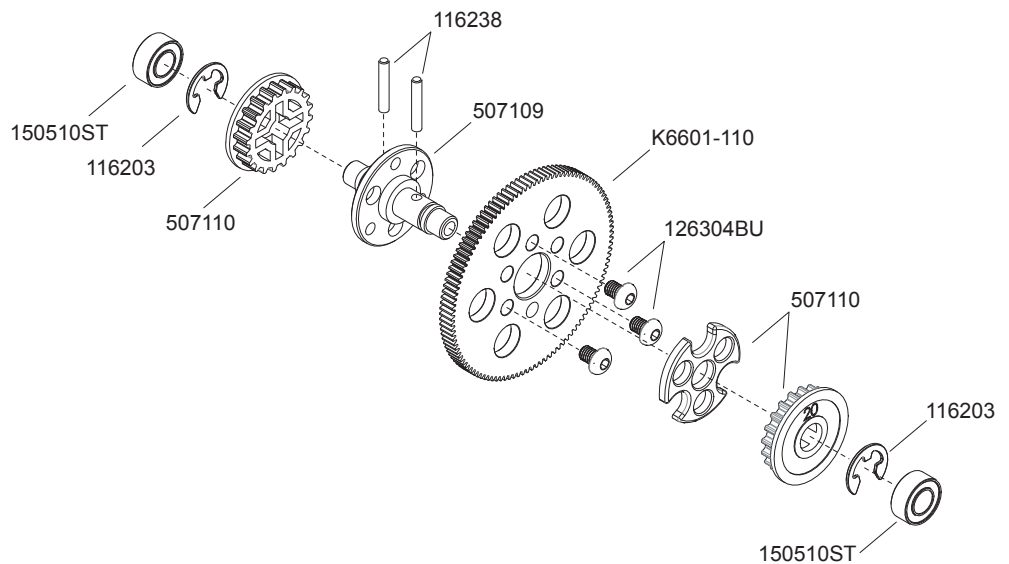
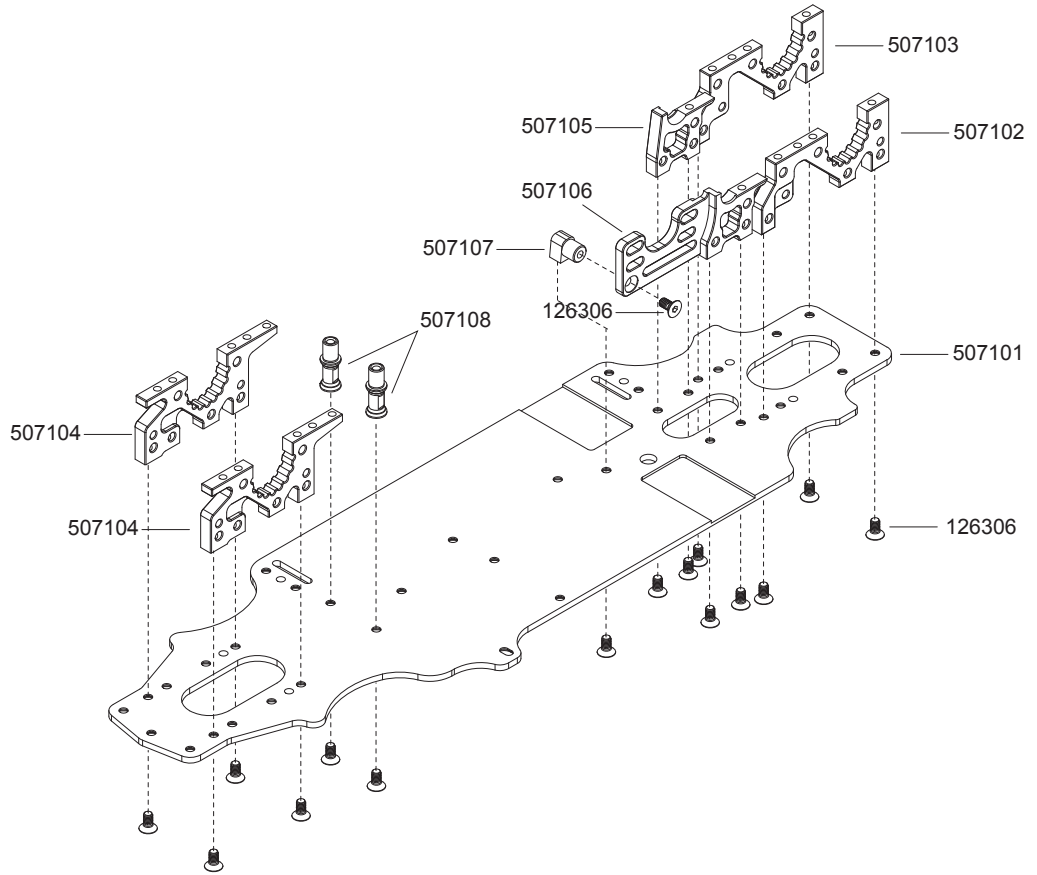



152011
3.8x1.9 O-RING



116239
1.5x6.8mm Pin



130103
4.2x10x0.2mm Shim



130123
2.6x8x0.1mm Washer



151015ST
10x15x4mm Steel
Bearing



126208
2.6x8mm Steel Flat
Head Screw

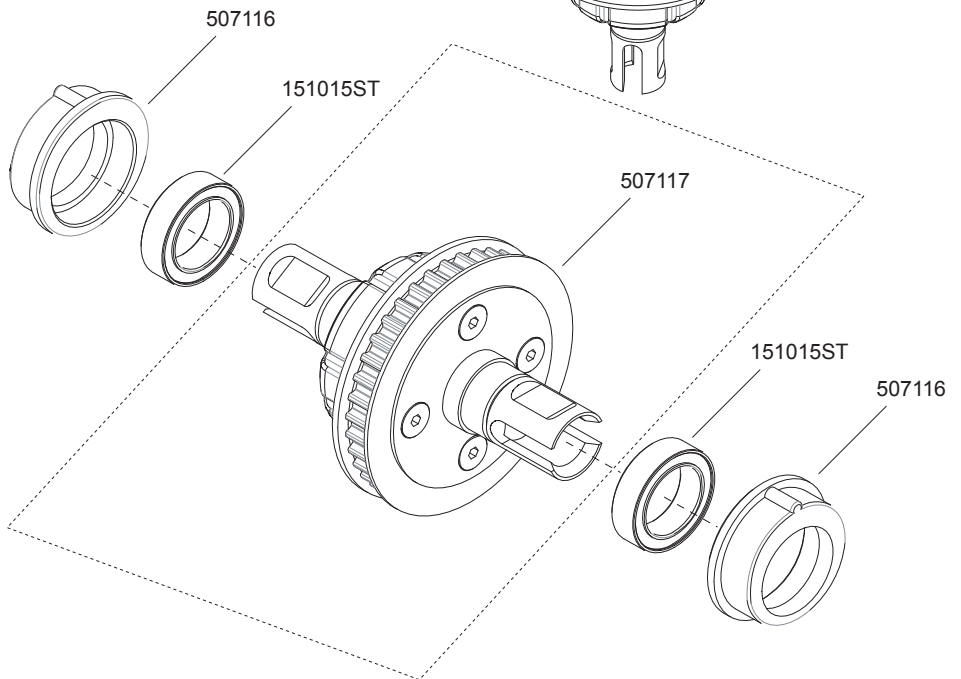
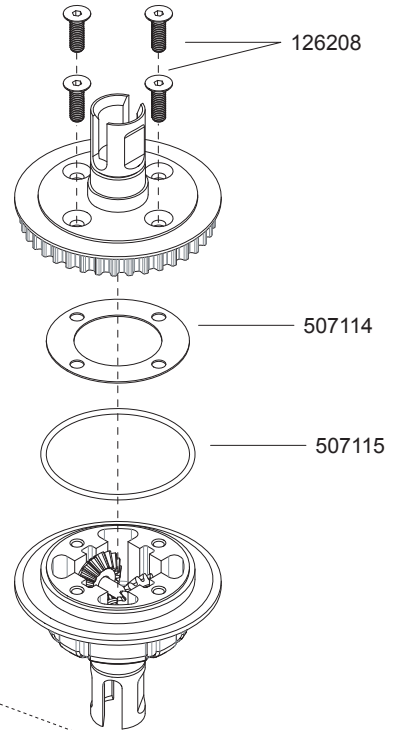
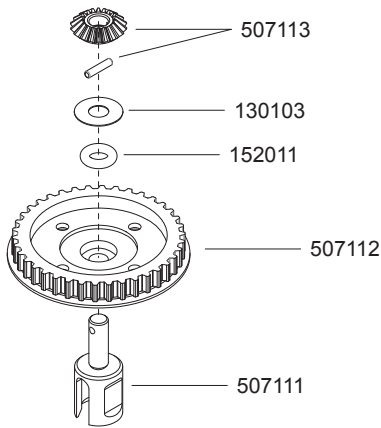
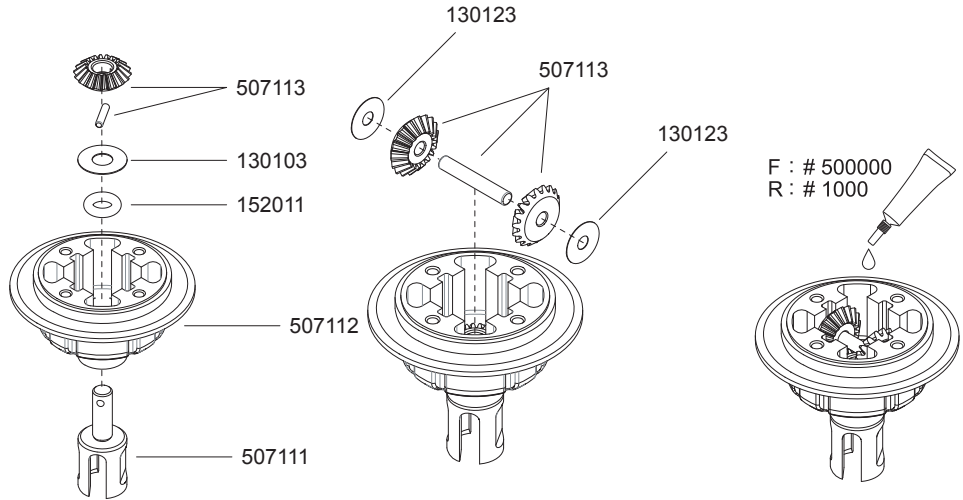



126310
3x10mm Steel F.H.
Screw



503117
5x4mm Ball Stud



126308BU
3x8mm Steel Button
Head Screw

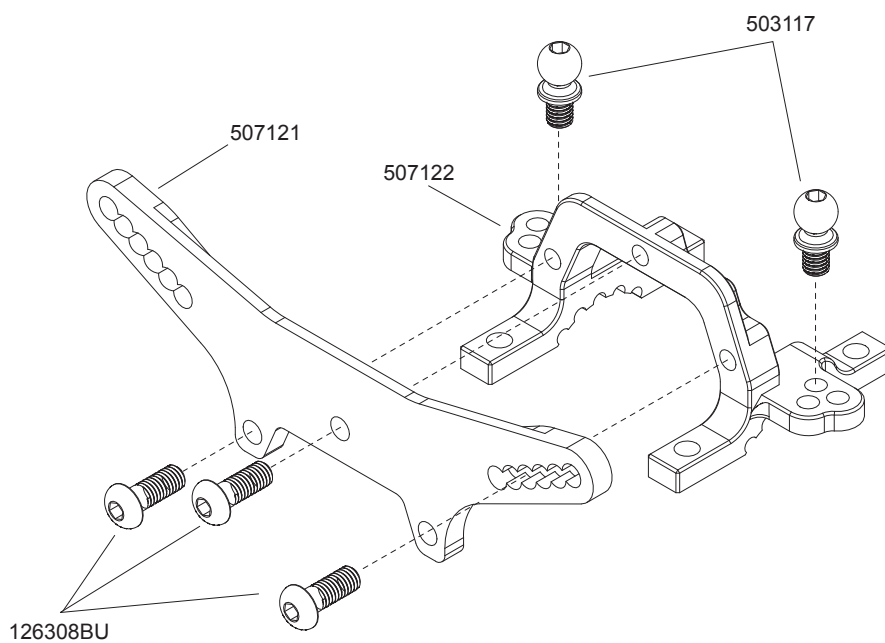
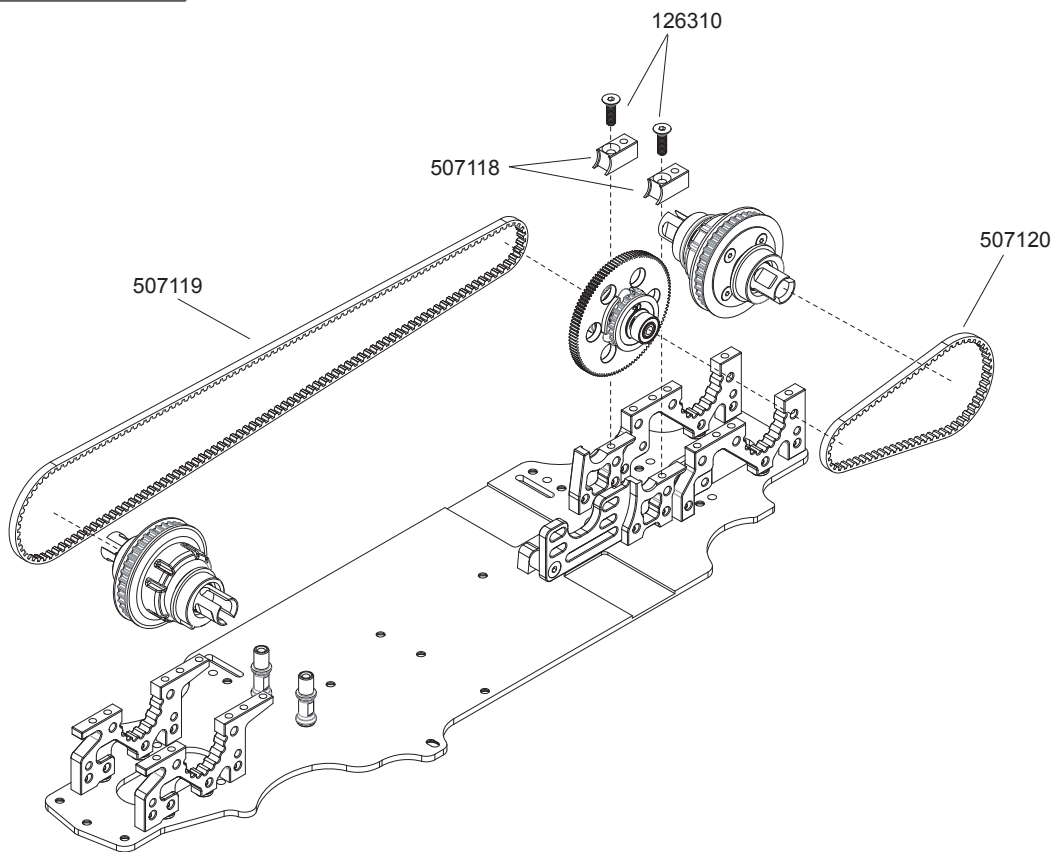



126308BU
3x8mm Steel Button
Head Screw



126212BU
2X12mm BH Screw



503117
5x4mm Ball Stud

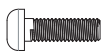

126310BU
3x10mm Button
Head Screw



126306BU
3x6mm Steel Button
Head Screw

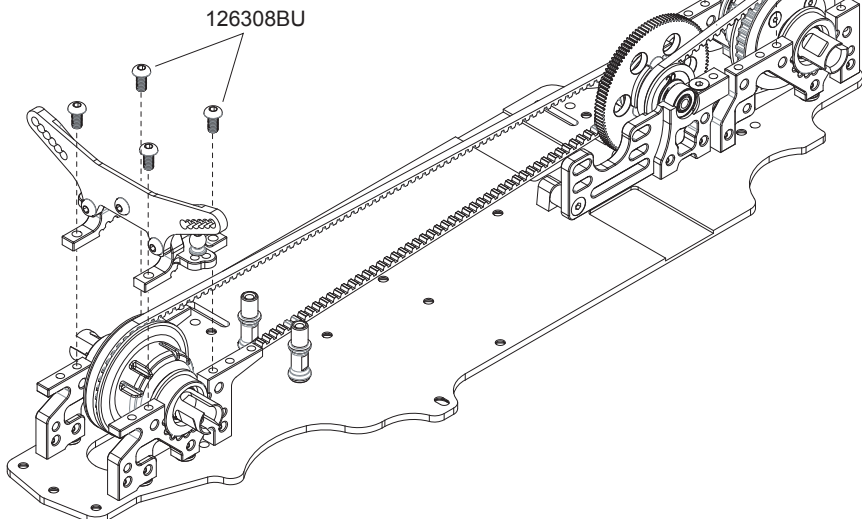
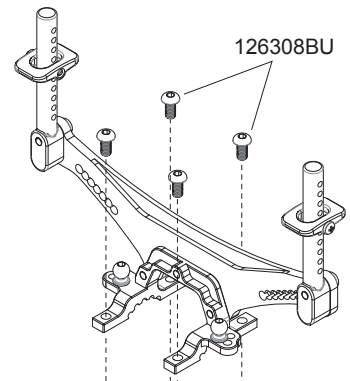
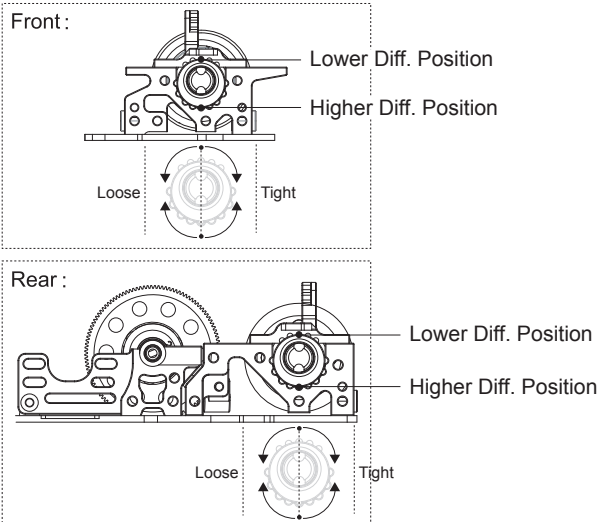
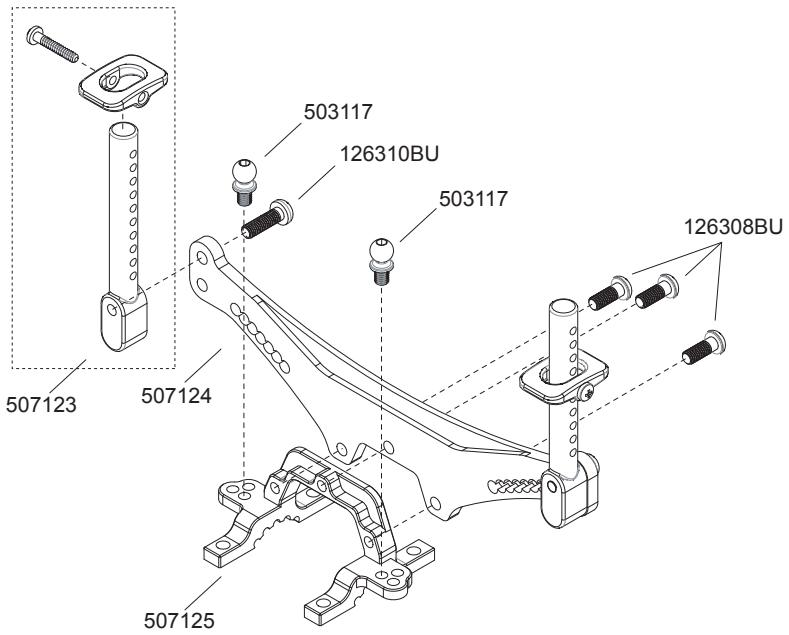



150508ST
5x8x2.5mm Steel
Bearing



150306ST
3x6x2.5mm Steel
Bearing



503117
5x4mm Ball Stud



126308
3x8mm Steel F.H.
Screw



126306BU
3x8mm Steel Button
Head Screw

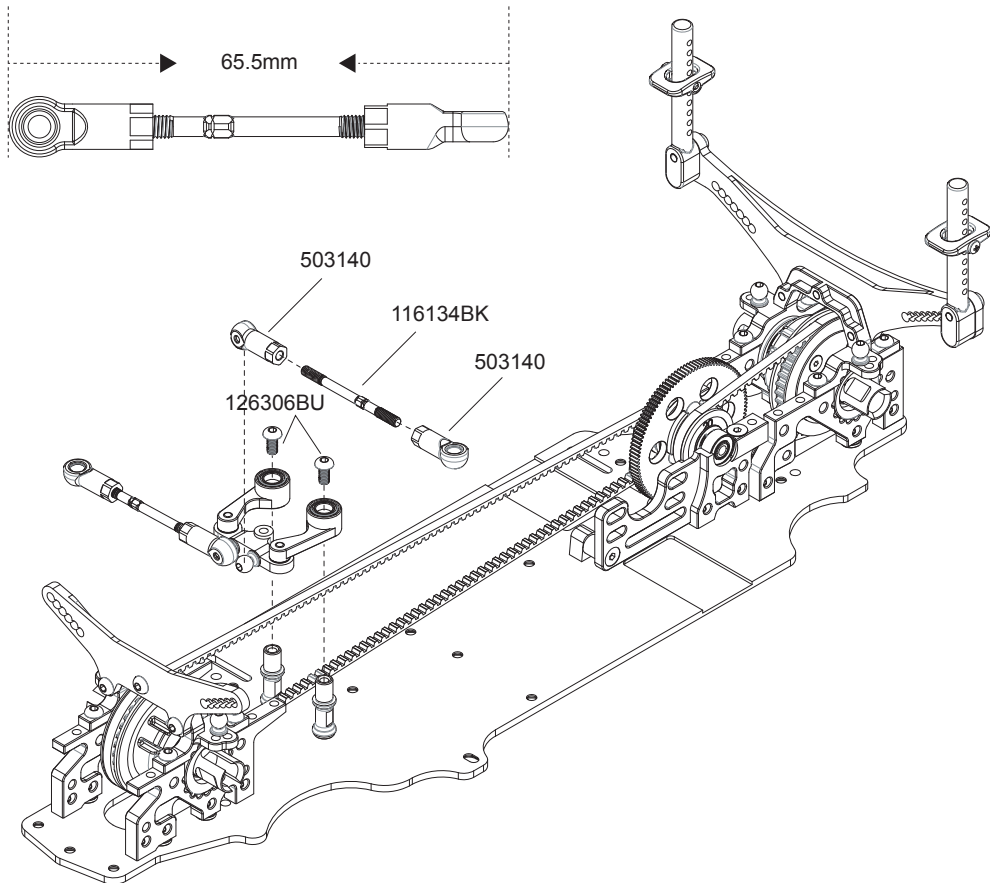
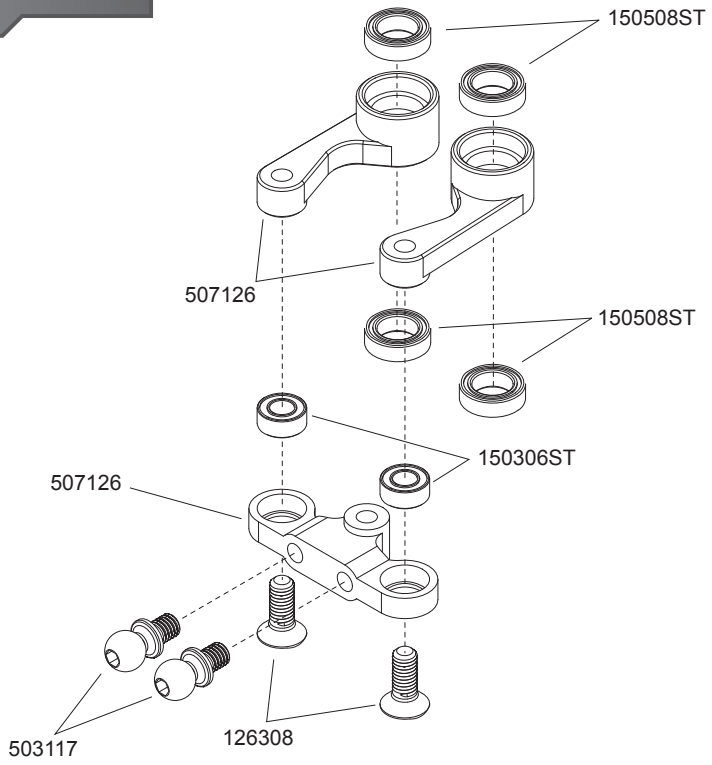



130114
3X6X1mm Washer



126408S
4x8mm Set Screw



126308S
M3X8mm Set



126204BU
2x4mm Steel Button
Head Screw



126316BU
M3X16mm BH Screw

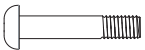

130124
3x7.5x1.5mm Washer



Roll Center Position

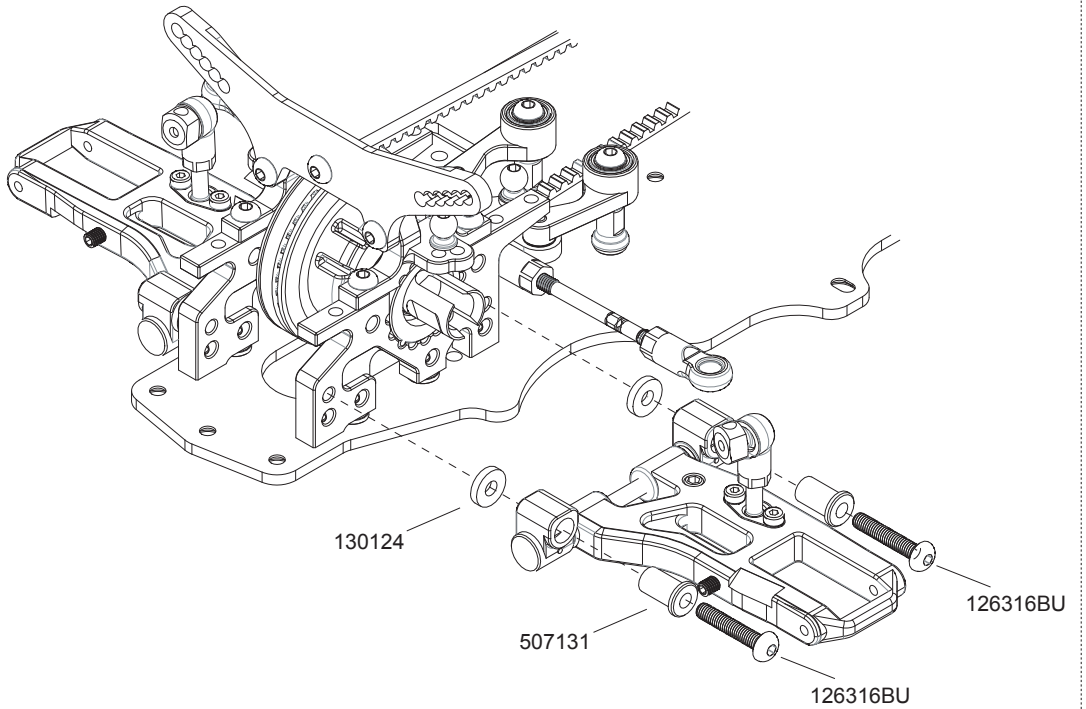
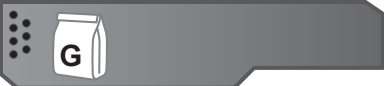
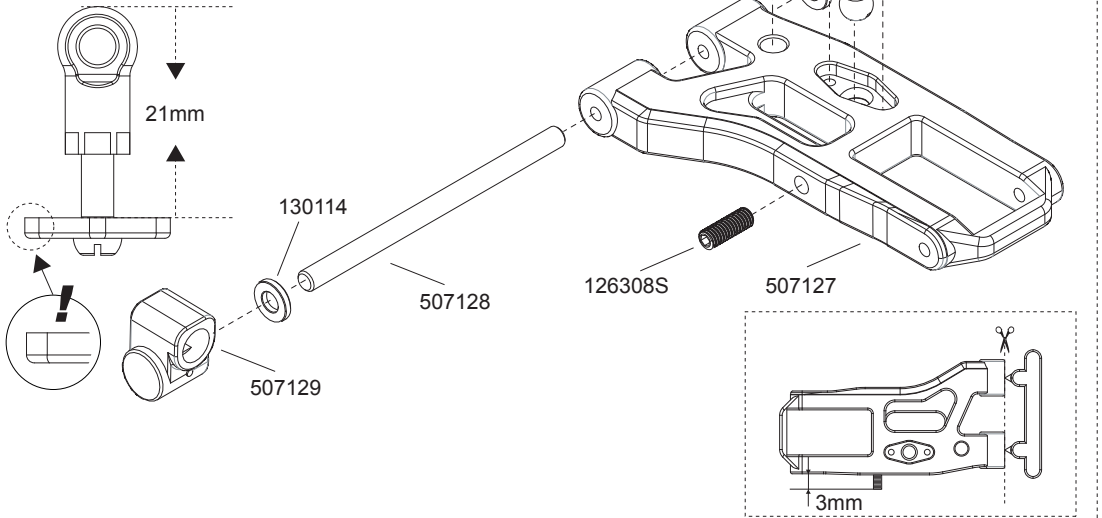
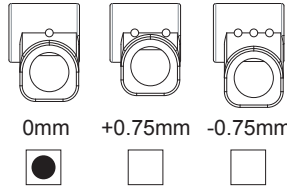



126408S
4x8mm Set Screw



130114
3X6X1mm Washer

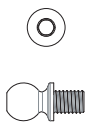

503117
5x4mm Ball Stud



126308S
M3X8mm Set



130124
3x7.5x1.5mm Washer



126316BU
M3X16mm BH Screw



126314BU
3x14mm Button
Head Screw

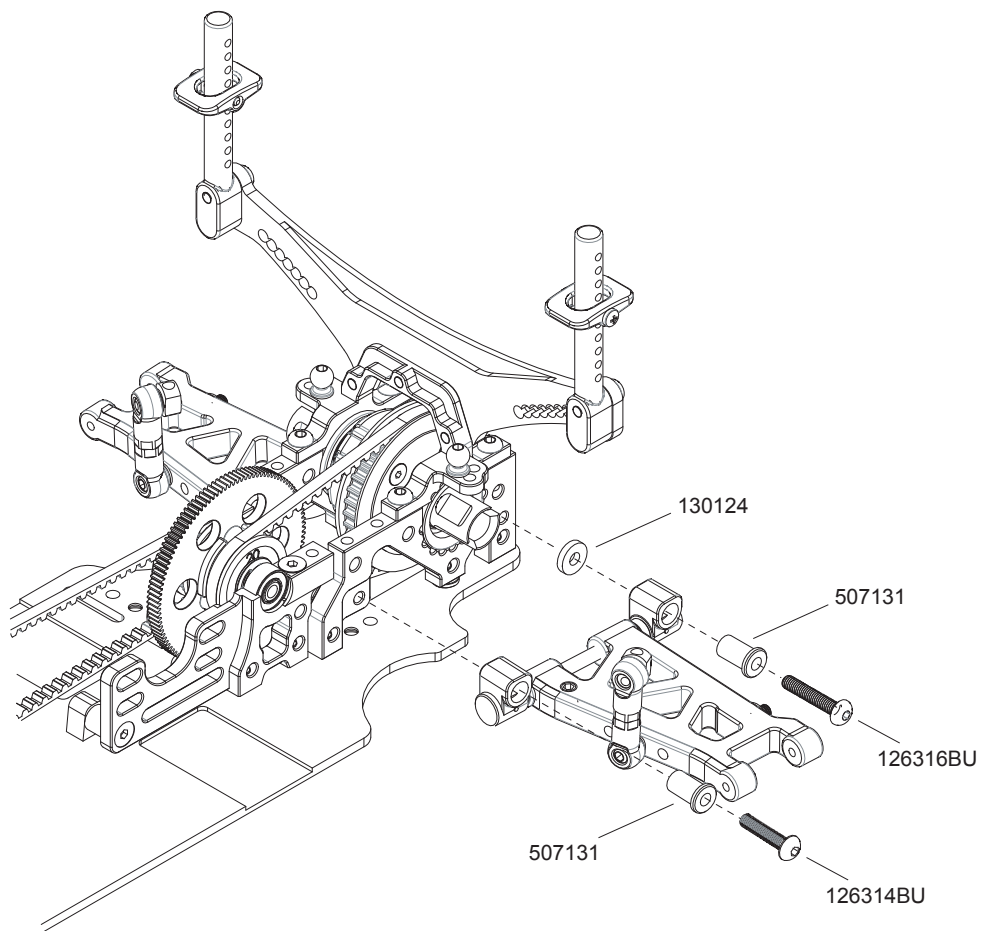
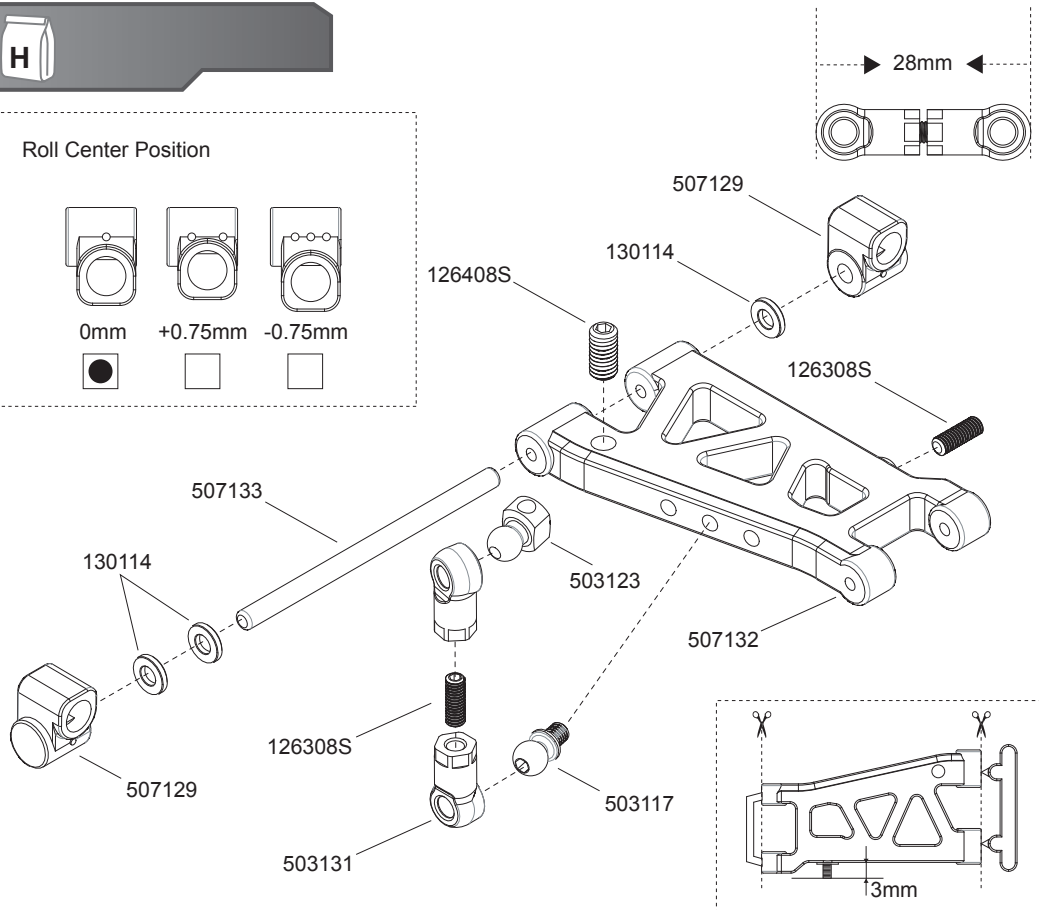
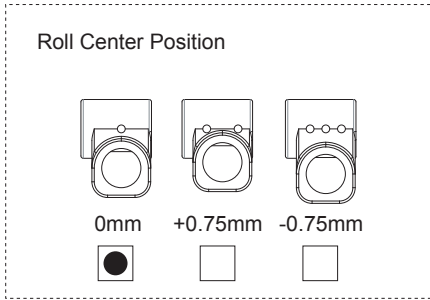



130114
3X6X1mm Washer



150510ST
5x10x4mm Steel
Bearing



116240
2x9.8mm Pin



126206C
2x6mm Cap Screw



507135 (Right)

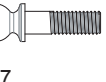

503127
Steering Block
5x10mm Ball Stud



126310BU
3x10mm Button Head
Screw



126302S
3x2mm Set Screw



150407ST
4x7x2.5mm Steel
Bearing



111165
3mm Flanged Nut

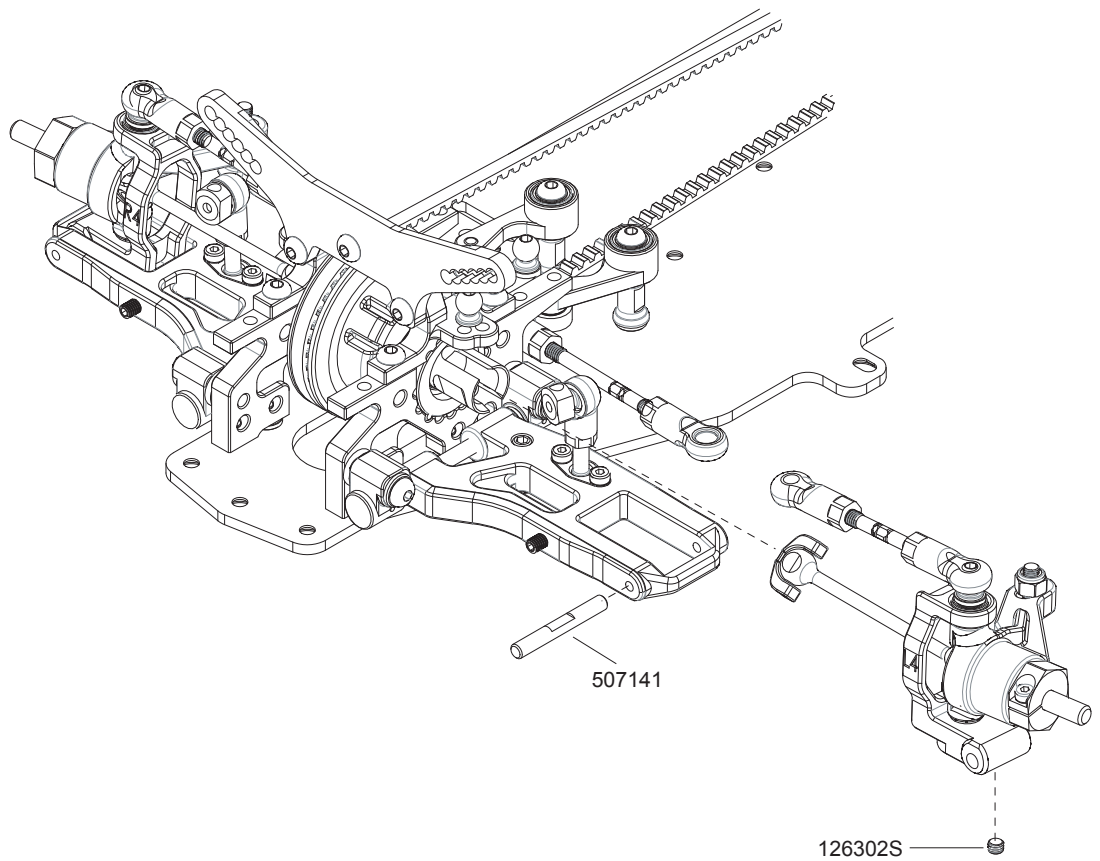
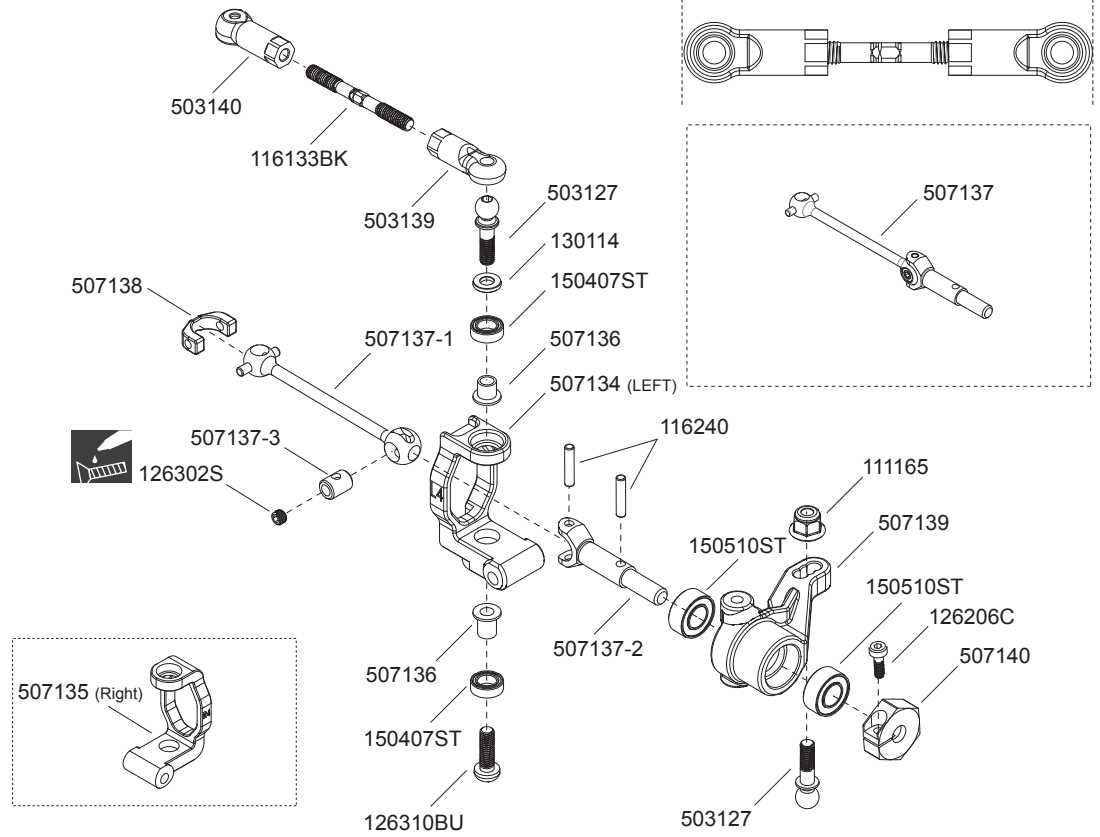



150510ST
5x10x4mm Steel
Bearing



116240
2x9.8mm Pin



126206C
2x6mm Cap Screw



116219
3x6x2mm Alum.
Washer



503127
Steering Block
5x10mm Ball Stud



126302S
3x2mm Set Screw



126303S
3x3mm Set Screw

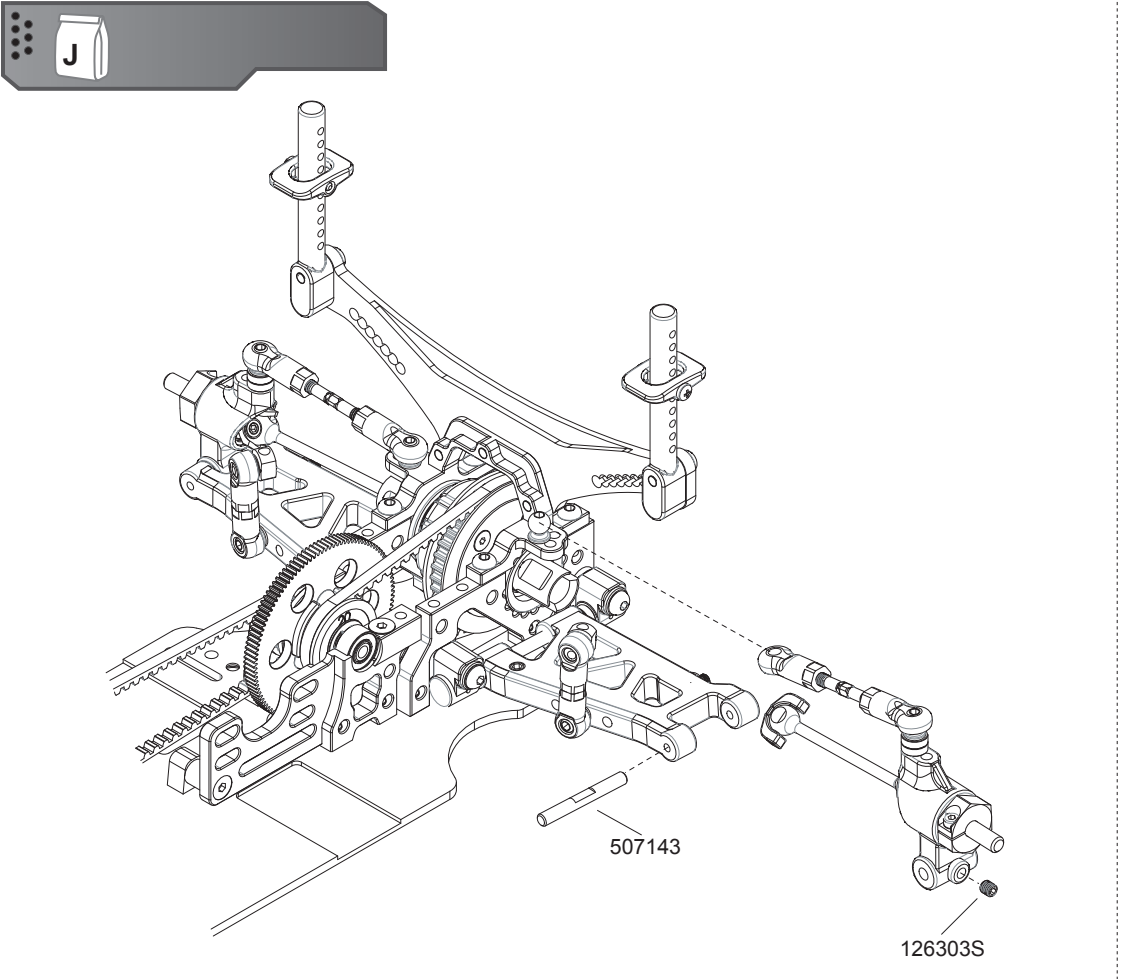
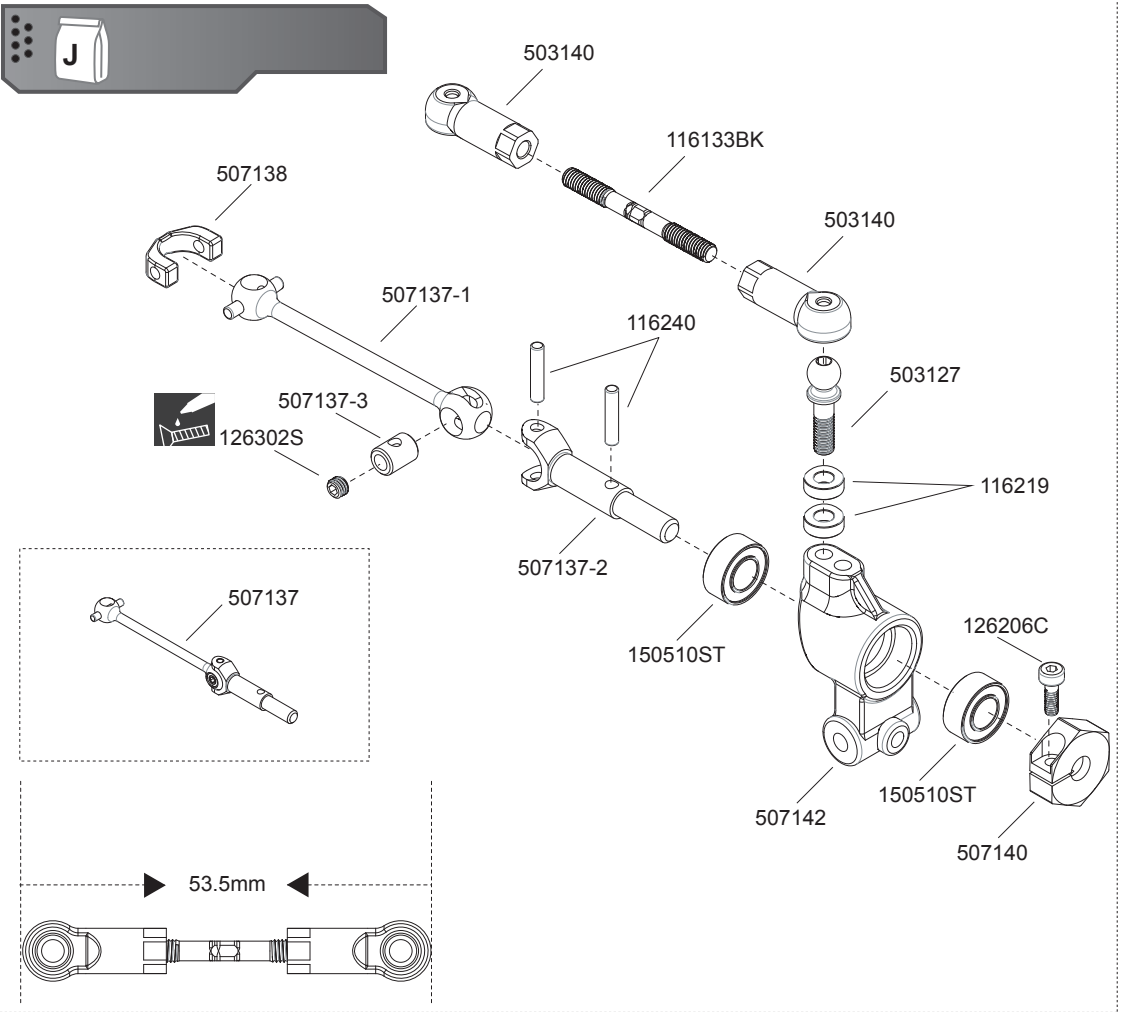



126303S
3x3mm Set Screw



126308BU
3x8mm Steel Button
Head Screw



126304S
3x4mm Set Screw

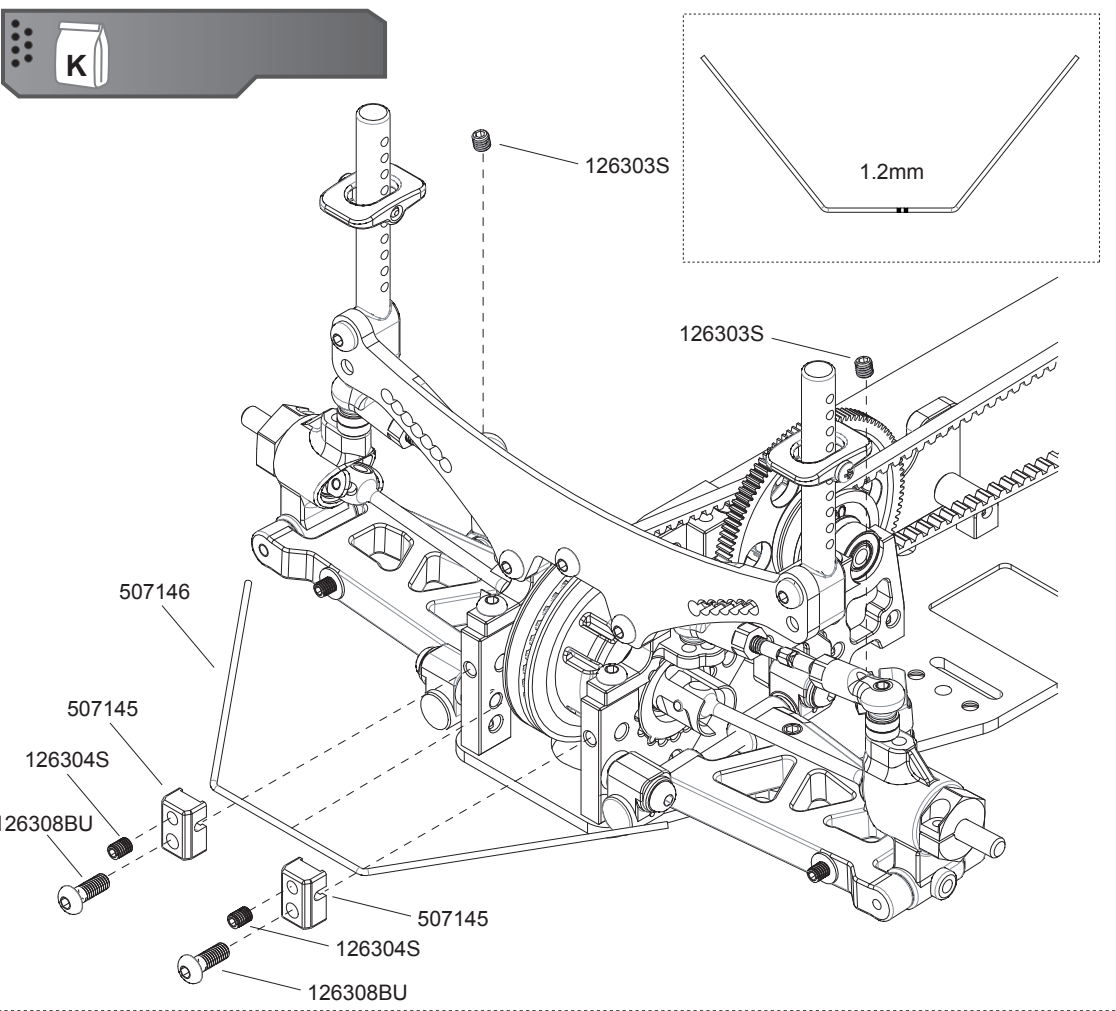
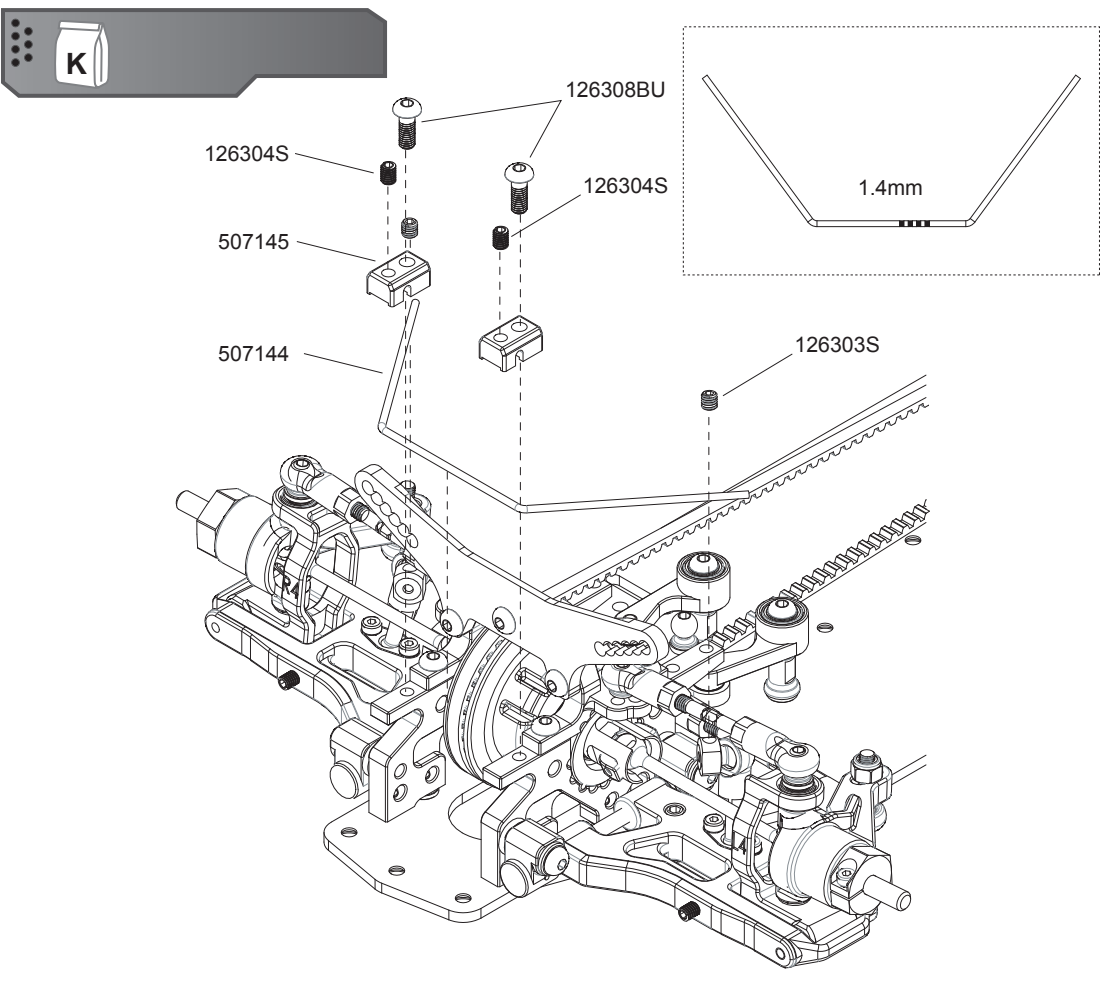



126308SE
3x8mm Steel Flat
Round Servo Mount
Screw



503138
5x7mm Ball Stud



503117
5x4mm Ball Stud



130125
3x6x4mm Alum.
Washer



126306
3x6mm Steel FH
Screw



126306BU
3x8mm Steel Button
Head Screw

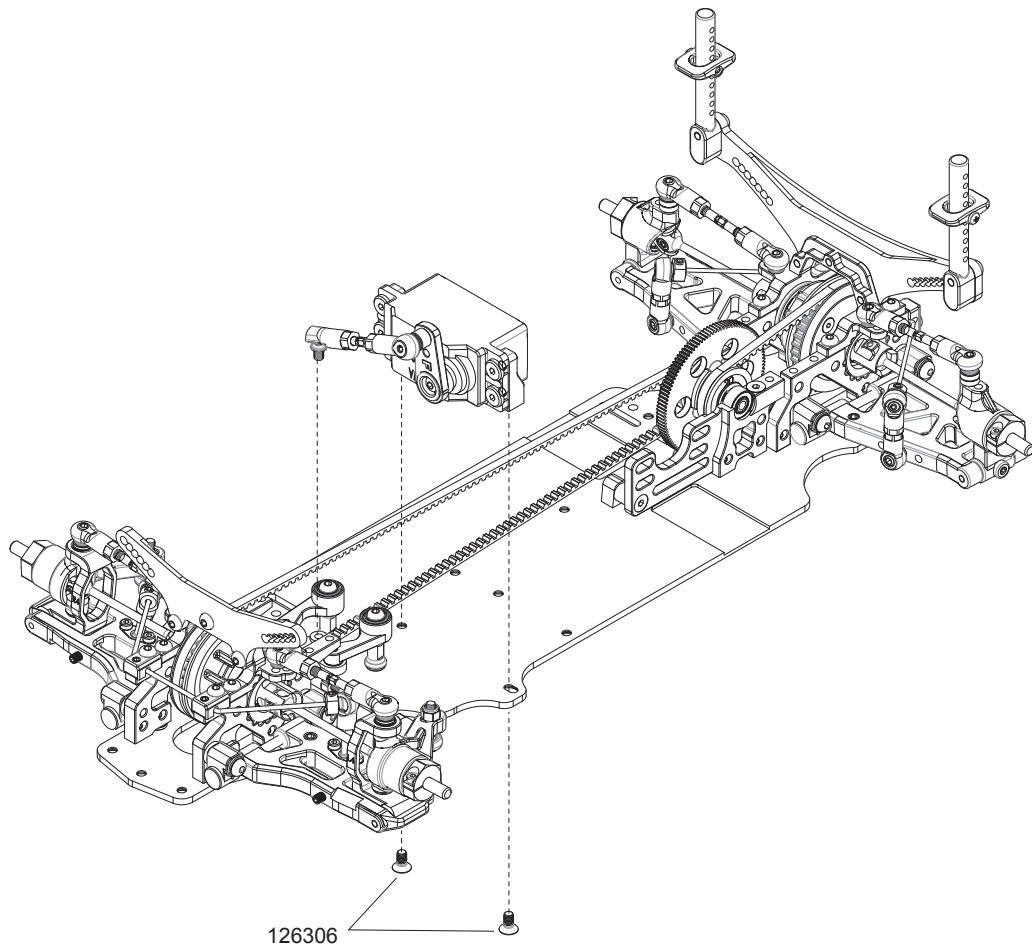
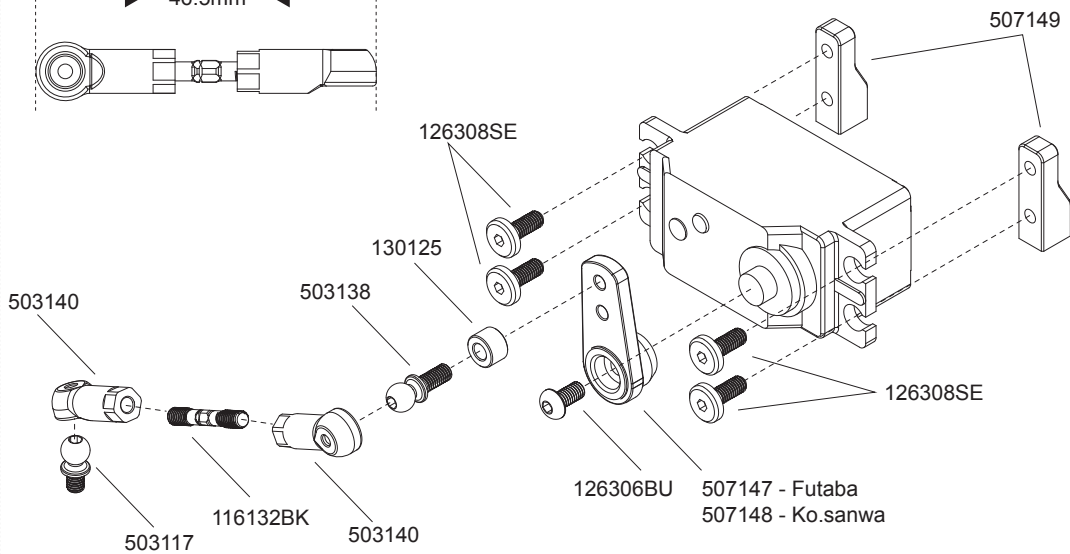
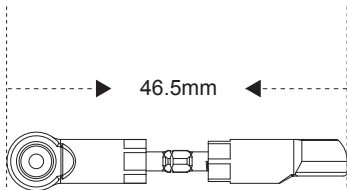



126306BU
3x6mm Steel Button
Head Screw



130114
3X6X1mm Washer



126314BU
3x14mm Button
Head Screw



126306
3x6mm Steel FH
Screw

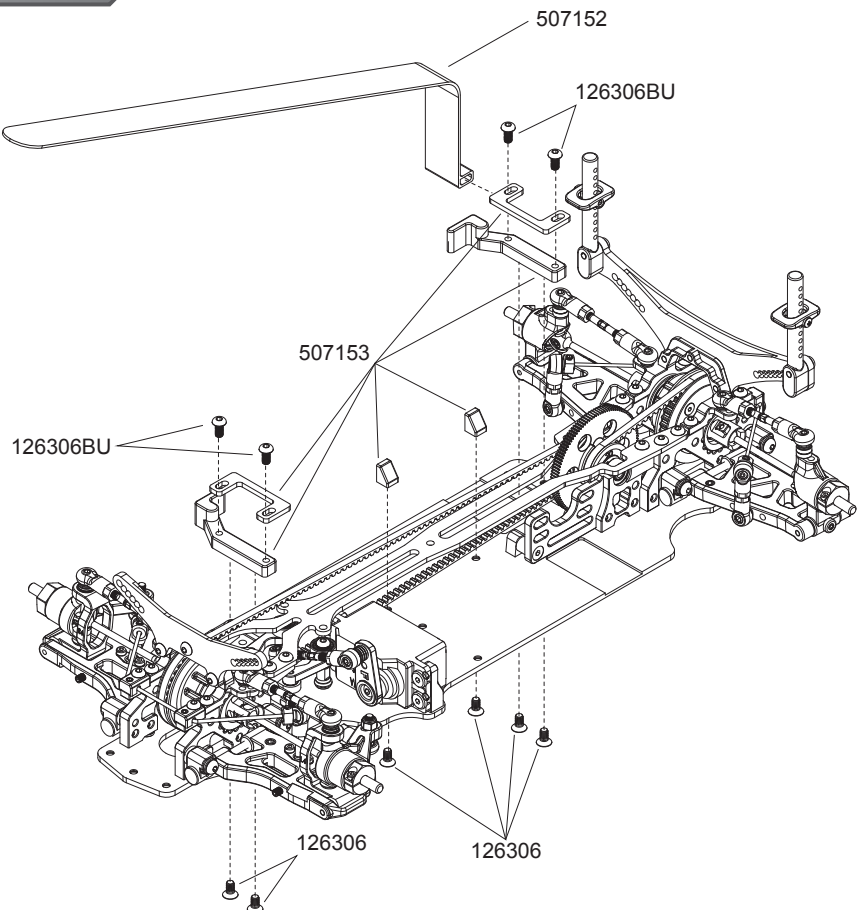
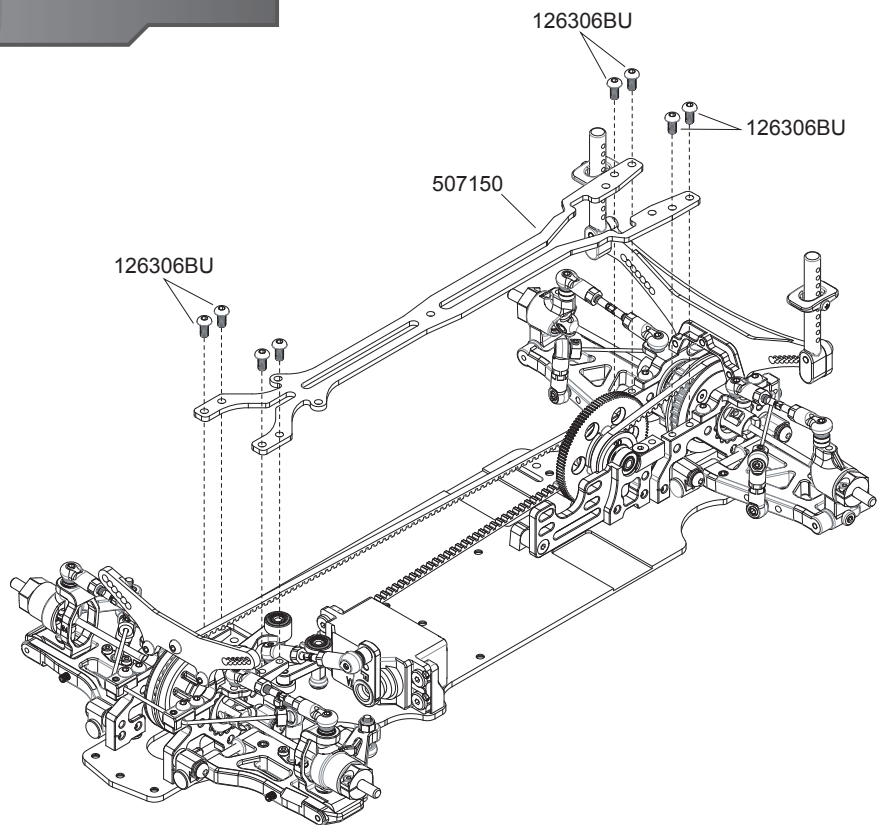



116227
E-clip 2.0



130111
2.6X6X0.5mm
Washer



126306BU
3x6mm Steel Button
Head Screw

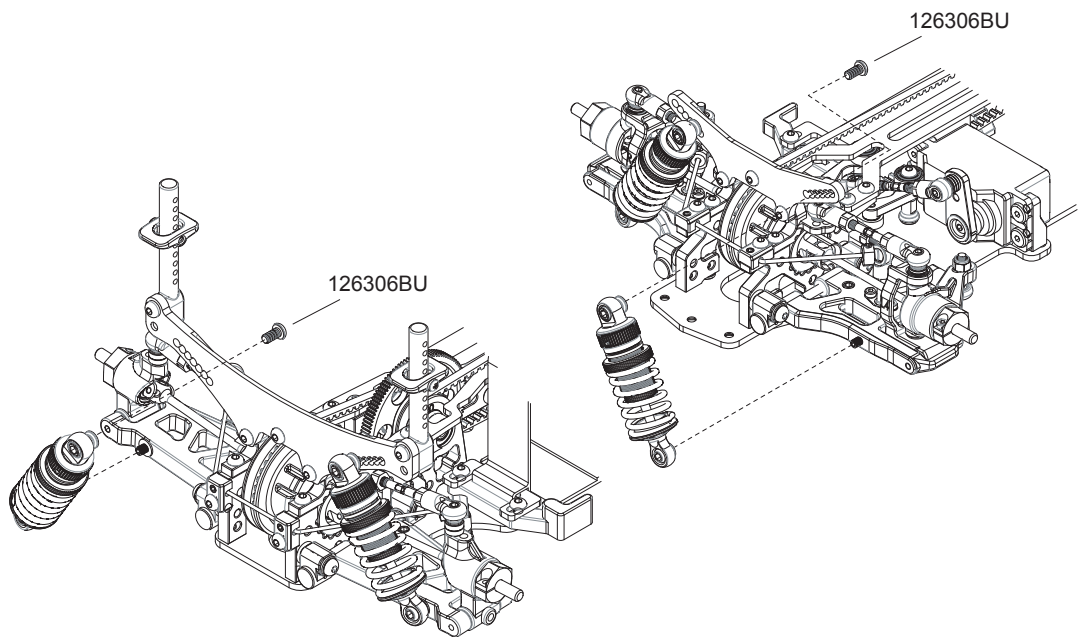
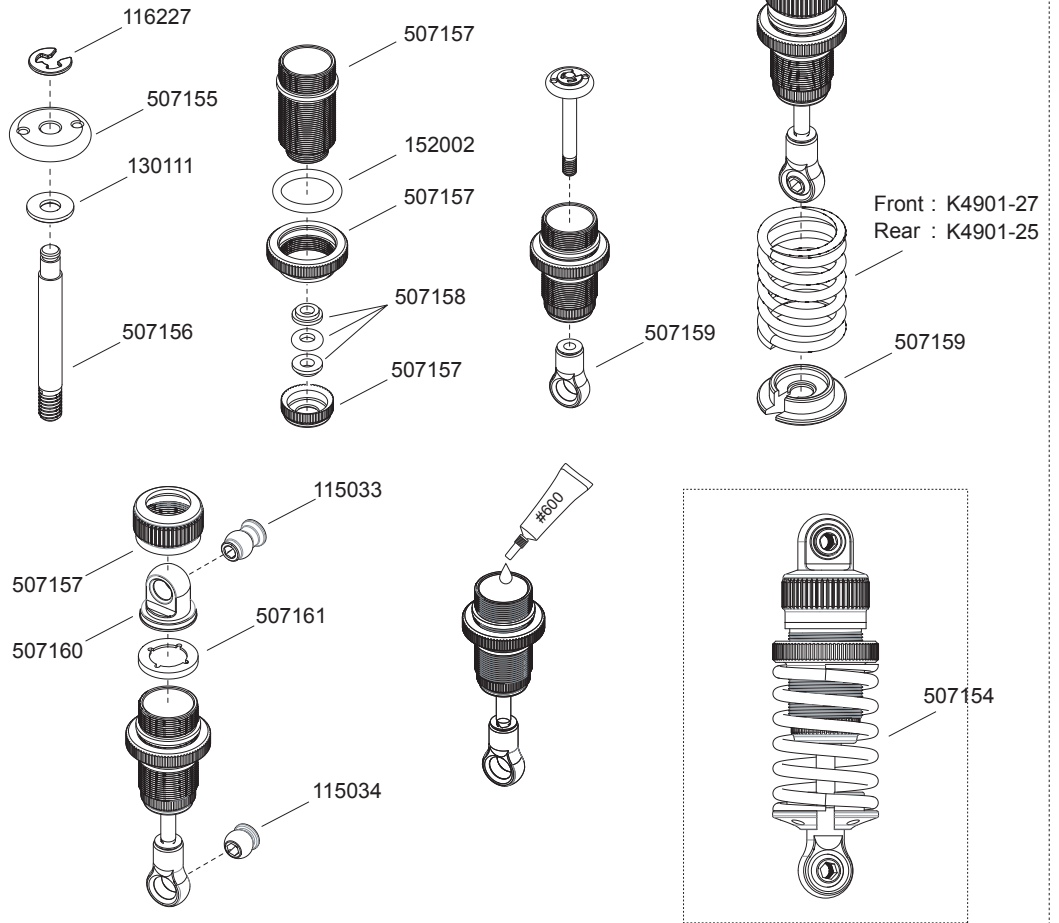



111007ST
3mm Steel Locknut



126308
3x8mm Steel F.H.
Screw



126212BU
2X12mm BH Screw



126310BU
3x10mm Button
Head Screw



126310
3x10mm Steel
F.H. Screw

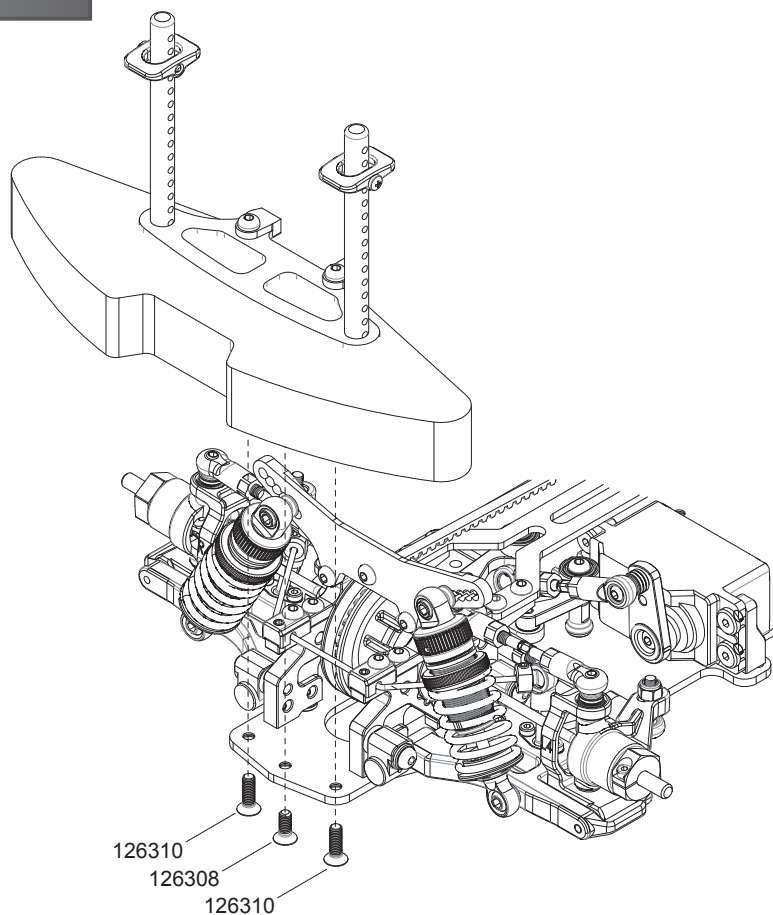
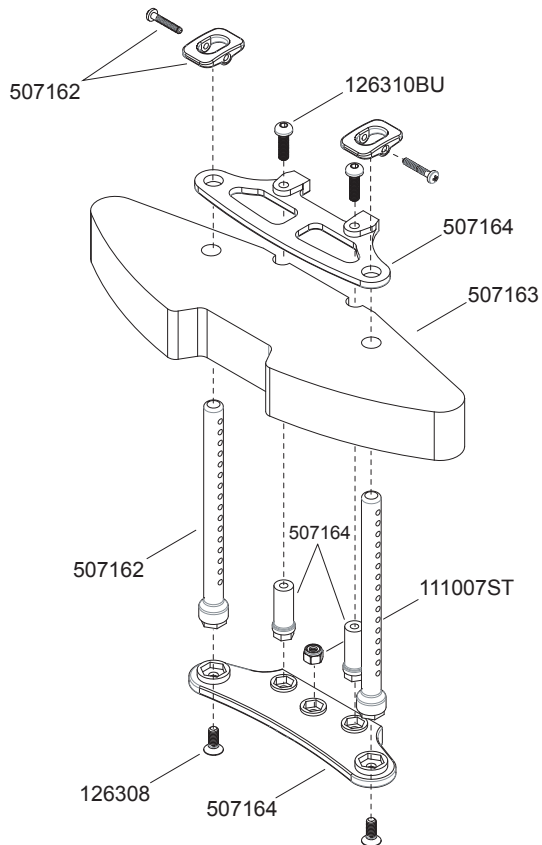
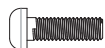



126306BU
3x6mm Steel Button
Head Screw



126306
3x6mm Steel FH
Screw

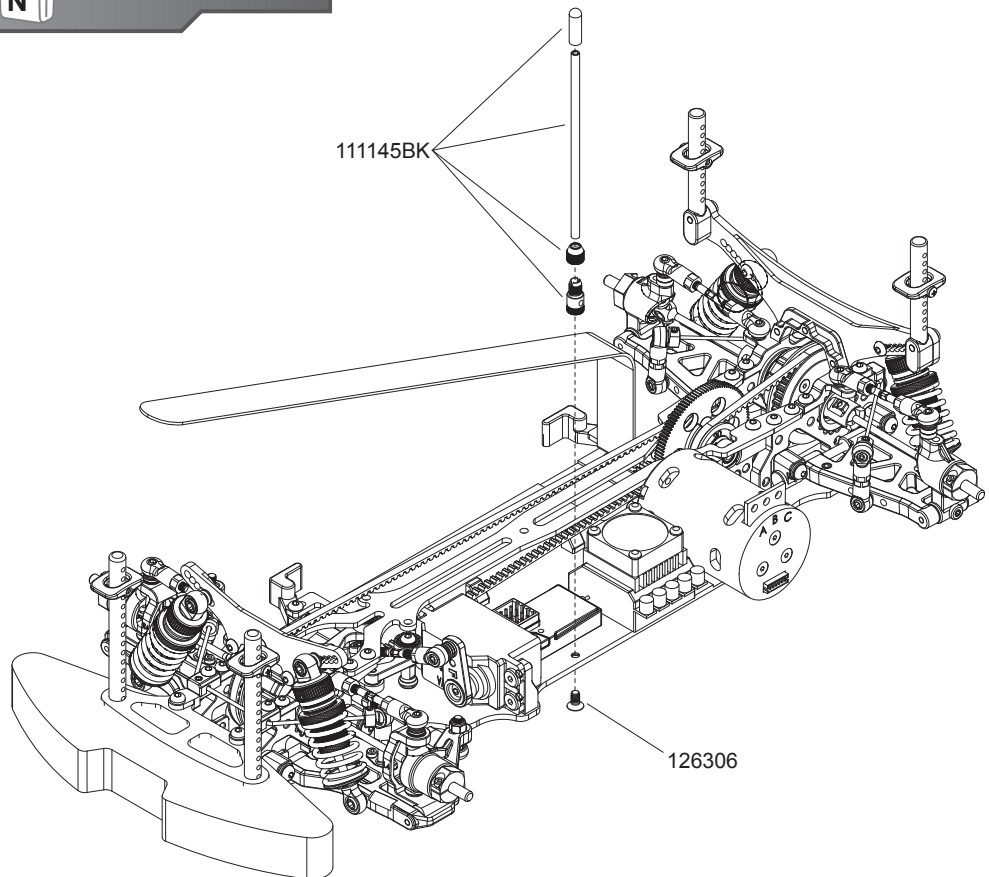
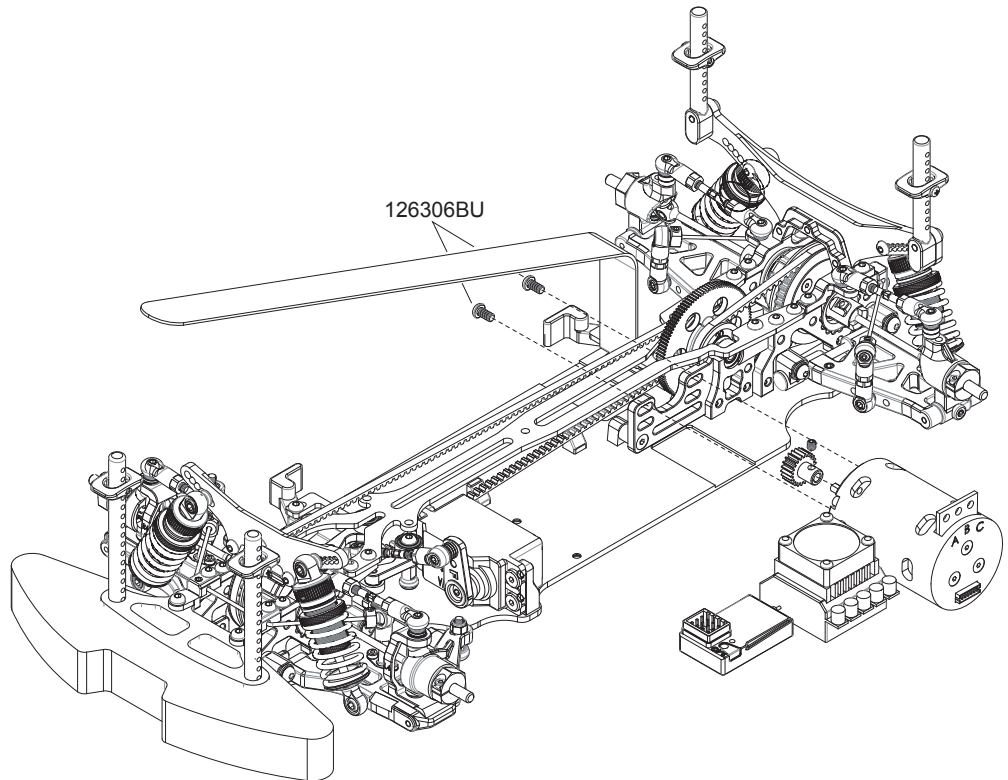



11046S
4mm Alum. Flanged
Lock Nut (Thin)
(4) SILVER

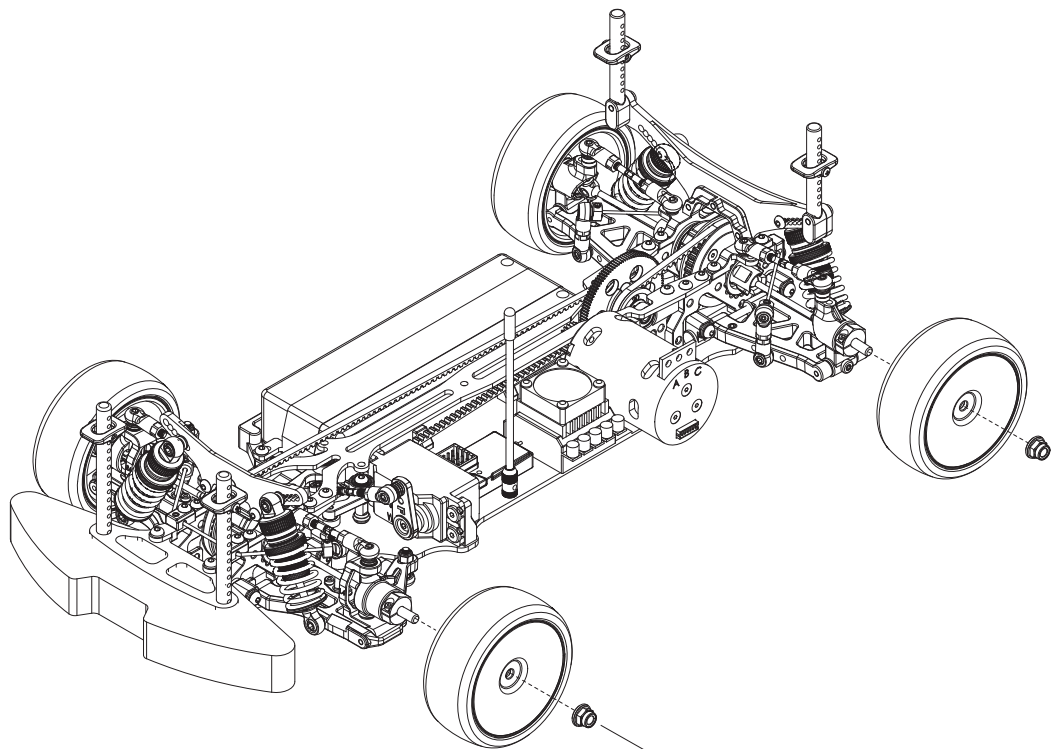
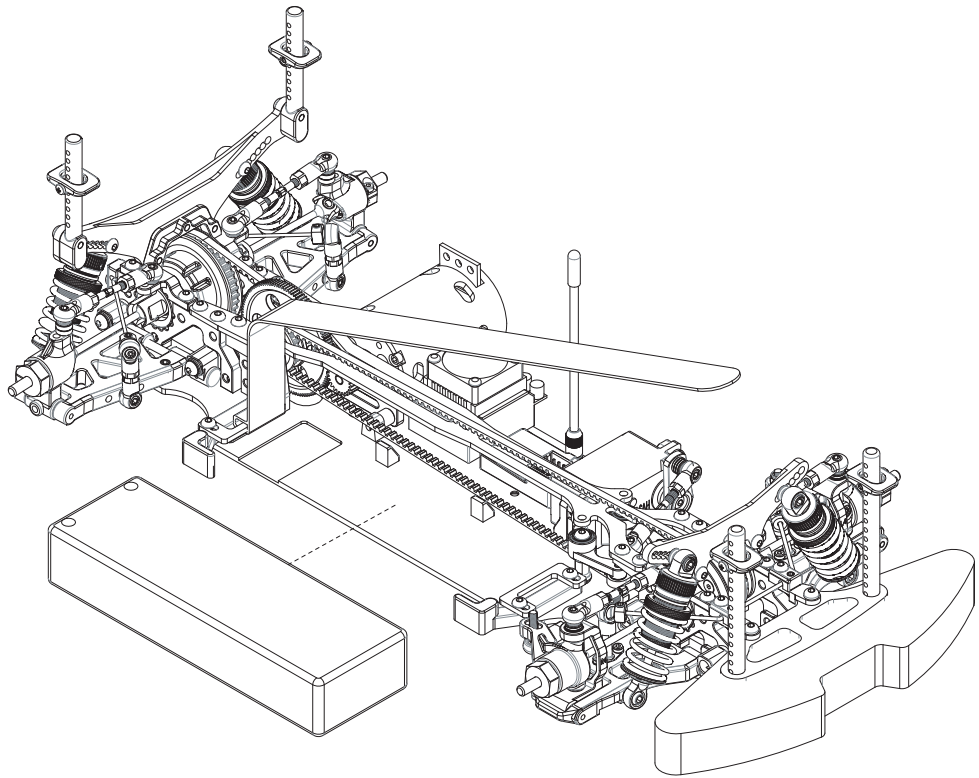

111046S

Stiff Setting

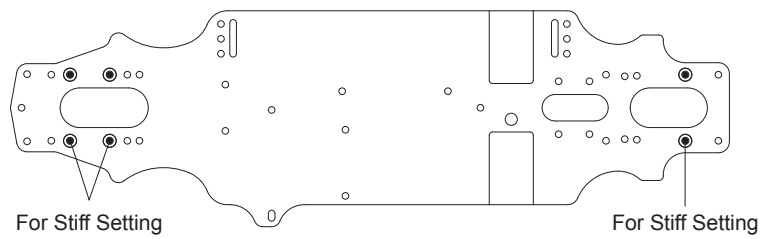
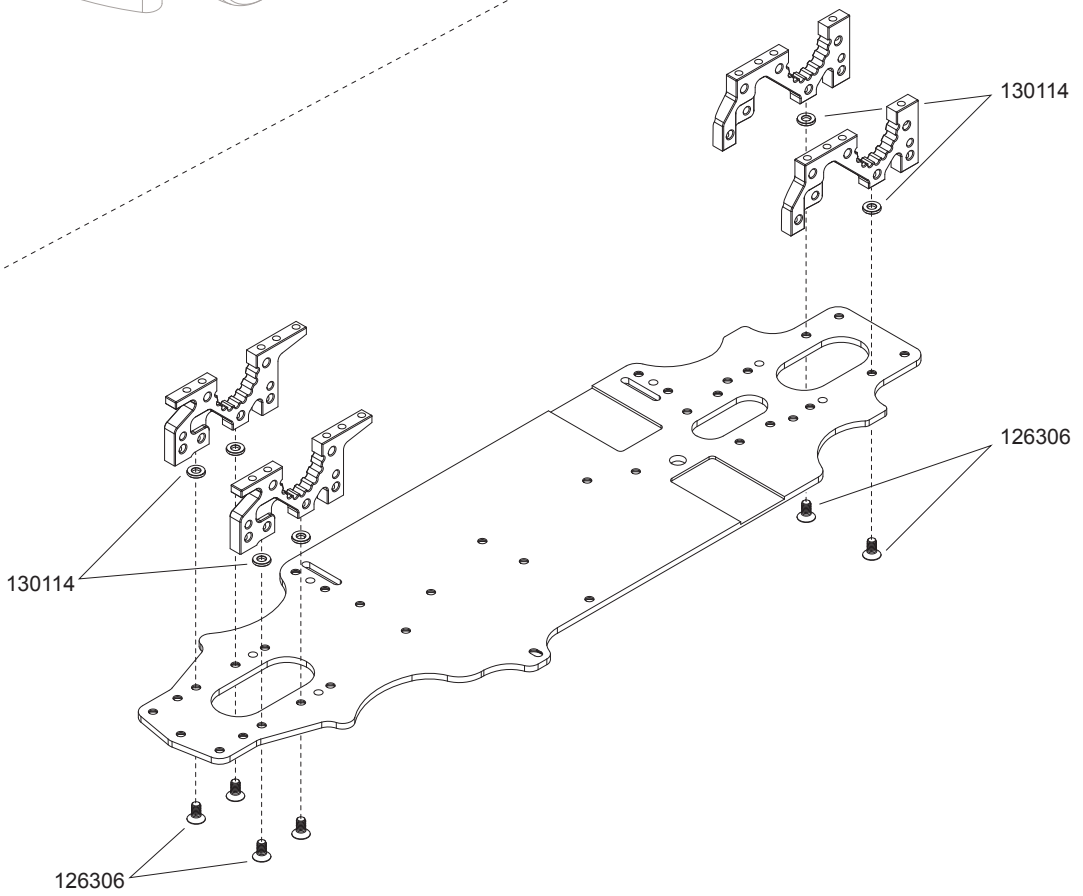
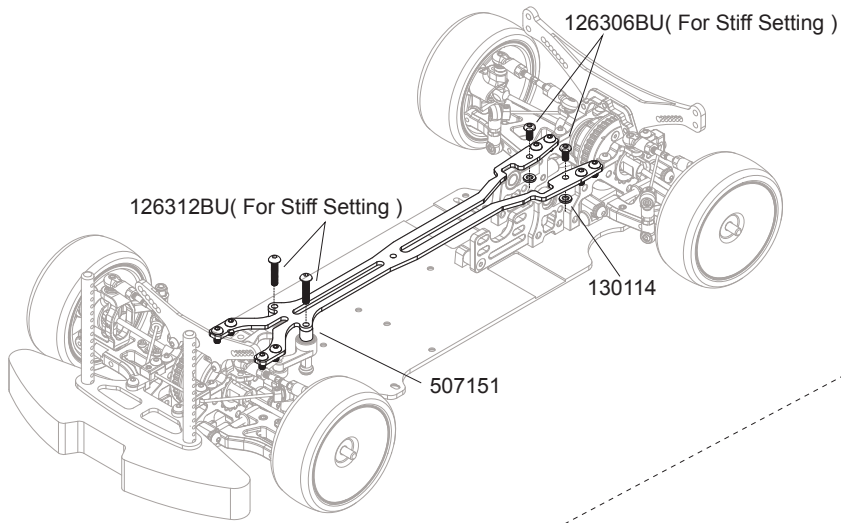

TRACK CONDITIONS			
Type :	<input type="checkbox"/> Carpet	<input type="checkbox"/> Asphalt	Size: <input type="checkbox"/> Open <input type="checkbox"/> Med. <input type="checkbox"/> Tight
Place :	<input type="checkbox"/> Indoor	<input type="checkbox"/> Outdoor	Traction: <input type="checkbox"/> High <input type="checkbox"/> Med. <input type="checkbox"/> Low
Surface:	<input type="checkbox"/> Smooth	<input type="checkbox"/> Med. <input type="checkbox"/> Bumpy	Track Temp/Air Temp: _____ / _____
Note: _____			

FRONT SUSPENSION

Track Width: 186 mm Gear Diff 500000 wt

Toe Angle: +1° Ball Diff

Caster: 4° One Way

Camber: -2° Solid Axle

Ride Height: 5 mm Anti-Roll Bar: \varnothing 1.4 mm

Down Stop: 6 mm

Shim: 1 mm

Shim: 0 mm

Shim: 1.5 mm

Shim: 1.5 mm

Shim: 0 mm

Shim: 1 mm

Shim: 1 mm

Diff. High Low

REAR SUSPENSION

Track Width: 189 mm Gear Diff 1000 wt

Toe Angle: -3° Ball Diff

Camber: -1.5° Solid Axle

Ride Height: 5.5 mm

Down Stop: 5 mm Anti-Roll Bar: \varnothing 1.2 mm

Shim: 4 mm

Shim: 0 mm

Shim: 0 mm

Shim: 1.5 mm

Shim: 1.5 mm

Shim: 2 mm

Shim: 1 mm

Diff. High Low

STIFF SETTING

ELECTRONICS

Servo: _____

ESC: _____

Battery: _____

DRIVE RATIO

Spur 110 T $\times 1.9 =$ _____

Pinion T _____

MOTOR

Brand: _____

Turns: _____

Timing: _____

TIRES

Insert: _____

Wheel: _____

Shore/deg: _____

Compound: _____

Tire Temp: _____

Tire additive: _____

Treated Area

FL FR RL RR

ESC

Punch: _____

Initial Brake: _____

Drag Brake: _____

ESC Timing Turbo Timing

SHOCKS

Hole Size: F 1.2 mm R 1.2 mm

Holes In Piston: F 2 R 2

Oil wt: F 600 R 600

Springs: F k-factory 034 R k-factory 035

Rebound: F _____ R _____

Bladder Note: _____

Thread Length: F _____ R _____

BODY

Body: _____

Wing Height: _____

Wing Position: _____



Parts List

PARTS	
Item No.	Item Description
507101	Chassis 2.3mm
507102	Alum. Rear Left Bulkhead
507103	Alum. Rear Right Bulkhead
507104	Alum. Front Bulkhead
507105	Alum. Main Shaft Right Bulkhead
507106	Alum. Motor Bulkhead
507107	Alum. Motor Bulkhead Support
507108	Alum. Steering Post (2)
507109	Alum. Spur Gear Holder
507110	20T Pulley (2)
507111	Alum. Diff. Joint (2)
507112	Diff. Case
507113	Bevel Gear Set (4)
507114	Diff. Case Gasket (4)
507115	Diff. Case O-ring (4)
507116	Belt Tension Adjuster (4)
507117	Gear Diff. Set
507118	Alum. Bearing Holder (2)
507119	Long Belt
507120	Short Belt
507121	Carbon Fiber Front Shock Tower
507122	Alum. Front Bulkhead Upper Mount
507123	Rear Body Support (2)
507124	Carbon Fiber Rear Shock Tower
507125	Alum. Rear Bulkhead Upper Mount
507126	Alum. Dual Steering Arm Set
507127	Front Suspension Arm (2)
507128	Front Suspension Pin (2)
507129	Suspension Arm Holder (2)
507130	Front Anti-roll Bar Rod (2)
507131	Alum. Bushing For Susp. Arm Holder (2)
507132	Rear Suspension Arm (2)
507133	Rear Suspension Pin (2)
507134	Alum. Caster Block Left (4 degree)
507135	Alum. Caster Block Right (4 degree)
507136	Bushing For Caster Block (2+2)
507137	Universal Driveshaft (2)
507137-1	Steel Drive Shaft Only (2)
507137-2	Steel Universal Joint Outdriver (2)
507137-3	Pivot for 507137 (2)
507138	Universal Driveshaft Plastic Pin Cover (8)
507139	Steering Block (2)
507140	Alum. Wheel Adapter (4)
507141	Caster Block Pin (2)
507142	Rear Hub Carrier (2)
507143	Rear Hub Carrier Pin (2)
507144	Front Anti-Roll Bar 1.4mm (2)
507145	Anti-Roll Bar Holder (4)
507146	Rear Anti-Roll Bar 1.2mm (2)
507147	Servo Arm (Futaba) (2)
507148	Servo Arm (Ko,Sanwa) (2)
507149	Alum. Servo Mount (2)
507150	Upper Plate 2.0mm
507151	Upper Plate Post (2)
507152	Quick Release Battery Strap
507153	Battery Holder Set
507154	Shock Absorber Set (2)
507155	Shock Piston 2 Holes (4)
507156	Shock Shaft (2)
507157	Shock Body Set (2)
507158	Shock Small O ring Set (4)

Item No.	Item Description
507159	Shock Ball End & Nylon Set(4)
507160	Shock Pivot (4)
507161	Shock Membrane (4)
507162	Front Body Support (2)
507163	Sponge Bumper
507164	Bumper Mount Set
503117	5x4mm Ball Stud (6)
503121	5mm Ball Cup - Short (6)
503123	Alum. Anti-Roll Bar Ball (4)
503127	Steering Block 5x10mm Ball Stud (4)
503138	5x7mm Ball Stud (6)
503139	Caster Block Ball Cup (4)
503140	5mm Ball Cup - Long (6)
111007ST	3mm Steel Locknut (10)
111046S	4mm Alum. Flanged Lock Nut (Thin) (4) SILVER
111165	3mm Flanged Nut(10)
115033	5.8mm Hex Socket Steel Ball-Long Neck (6)
115034	5.8mm Hex Socket Steel Ball-Short Neck (6)
116132BK	3x20mm Adjustable Rod (2)-BK
116133BK	3x30mm Adjustable Rod (2)-BK
116134BK	3x40mm Adjustable Rod (2)-BK
116203	E-clip 5 (10)
116219	3x6x2mm Alum. Washer (6)
116227	E-clip 2.0 (10)
116238	2x12.8mm Pin (10)
116239	1.5x6.8mm Pin (10)
116240	2x9.8mm Pin (10)
126208	2.6x8mm Steel Flat Head Screw(6)
126204BU	2x4mm Steel Button Head Screw (6)
126206C	2x6mm Cap Screw (6)
126212BU	2X12mm BH Screw(10)
126302S	3x2mm Set Screw (6)
126303S	3x3mm Set Screw (6)
126304BU	M3X4mm BH Screw(10)
126304S	3x4mm Set Screw (6)
126306	3x6mm Steel FH Screw (6)
126306BU	3x6mm Steel Button Head Screw (6)
126308	3x8mm Steel F.H. Screw (6)
126308S	M3X8mm Set(10)
126308SE	3x8mm Steel Flat Round Servo Mount Screw (6)
126308BU	3x8mm Steel Button Head Screw (6)
126310	3x10mm Steel F.H. Screw (6)
126310BU	3x10mm Button Head Screw (6)
126314BU	3x14mm Button Head Screw (6)
126316BU	M3X16mm BH Screw(10)
126408S	4x8mm Set Screw (6)
130103	4.2x10x0.2mm Shim (6)
130111	2.6X6X0.5mm Washer(10)
130114	3X6X1mm Washer(10)
130123	2.6x8x0.1mm Washer (10)
130124	3x7.5x1.5mm Washer (10)
130125	3x6x4mm Alum. Washer (6)
150306ST	3x6x2.5mm Steel Bearing(4)
150407ST	4x7x2.5mm Steel Bearing(4)
150508ST	5x8x2.5mm Steel Bearing(4)
150510ST	5x10x4mm Steel Bearing (4)
151015ST	10x15x4mm Steel Bearing (4)
152002	O-RING 11.2 x 1.7 (10)
152011	3.8x1.9 O-RING (10)
K4901-25	LX Touring Shock Spring 13x23.5mm #25
K4901-27	LX Touring Shock Spring 13x23.5mm #27
K6601-110	Special Precision 64P Spur Gear 110T